

Pneumatic Cylinder

New T-DYNAMO (7E/7F/7G)

We have pursued top-level performance that carries on the excellence of the T-matic cylinder, our top-selling pneumatic actuator for butterfly valves. Employing an NAMUR mount, this unit is compact and lightweight, and offers high output and further heightened perfection as a complete system.



Features

- Direct valve installation with bottom ISO mounting.
- Completely direct mounting of valve installation section.
- NAMUR mount at pneumatic port connections and accessories interface.

New T-DYNAMO Standard specifications									
	Double-acting type (7E)					Single-acting type (7F / 7G)			
Type	T35	T85	T200	T380	T750	T85S	T200S	T380S	T750S
Torque (N·m)(When supply pressure is 0.4MPa and rotation angle is 0°)	35	85	200	380	750	30	65	116	240
Supply air pressure condition/temperature	-10 to 60 degrees C								
Air Supply Pressure	0.4 to 0.7MPa								
Body shell max (MPa)	1.05MPa								
Air connection (Rc)	Rc(PT) 1/4								
Rotating angle	90°								
Ambient temperature	-10 to 60 degrees C								
Travel time(sec) with speed controller	1 to 15 sec	2 to 15 sec	3 to 15 sec	7 to 20 sec	12 to 25 sec	2 to 15 sec	6 to 15 sec	8 to 20 sec	15 to 25 sec

※The opening and closing times are the times in the case of a single unit of a cylinder with a standard speed controller (SP-K017-Z03-006) and a solenoid valve (PCS2408-03-100MC) when the air supply pressure is 0.4MPa. The opening and closing times depend on pneumatic piping system, etc.

New T-DYNAMO Principle of operation

Double-acting type cylinder

- (1) The cylinder space which is enclosed by the case ① and the covers ⑥ and ⑦ is divided into airtight chambers ④ and ⑤ by the pistons ⑤ and the piston packing ④.
- (2) The shaft ② penetrates the chamber ⑤ of the case. The yoke ③ is fitted in the hole across the shaft in such a way that it allows it to slide in the hole. The top of the yoke is connected with the parallel pins ② so it rotates in accordance with the movement of the pistons.
- (3) The compressed air enters chamber ④ through port A and pushes the pistons. The air in chamber ⑤ is exhausted through port B as the pistons move due to a pressure difference between the two chambers. Integrated with these pistons, the parallel pins ② also move and torque in the shaft is generated.

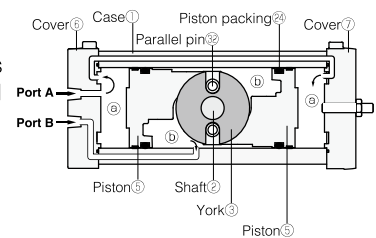

Single-acting type cylinder

- (1) The cylinder space which is enclosed by the case ① and the covers ⑥ and ⑦ is divided into airtight chambers ④ and ⑤ by the pistons ⑤ and the piston packing ④.
- (2) The shaft ② penetrates the chamber ⑤ of the case. The yoke ③ is fitted in the hole across the shaft in such a way that it allows it to slide in the hole. The top of the yoke is connected with the parallel pins ② so it rotates in accordance with the movement of the pistons.
- (3) The compressed air enters chamber ⑤ through port B and pushes the pistons. The air in chamber ④ is exhausted through port C as the pistons ⑤ move and the spring ④ is squeezed due to a pressure difference between the two chambers. Integrated with these pistons ⑤, the parallel pins ② also move and torque in the shaft is generated.
- (4) When air supply to Port B is stopped, the pistons are pushed back due to the force of the spring ④ and torque in the shaft is generated.

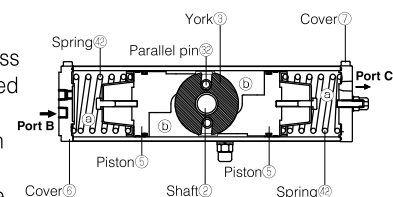

New T-DYNAMO Dimensions

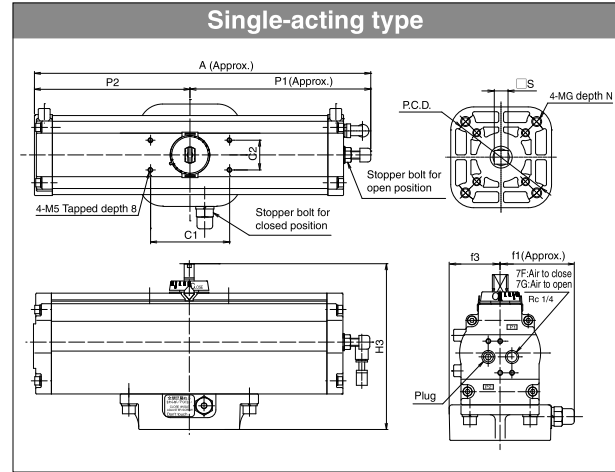
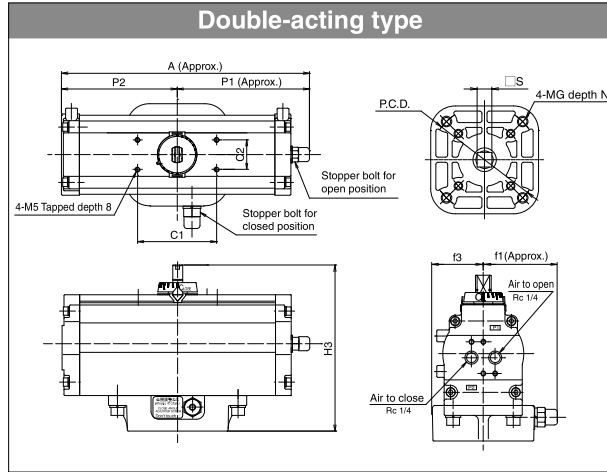

New T-DYNAMO Dimension list

Cylinder type	Dimension (mm)											Cylinder capacity (liter/lst)	Approx. Mass (kg)				
	A	P1	P2	H3	C1	C2	f1	f3	S	MG	N						
T35	P.C.D.70																
T85	P.C.D.70	251	134	117	168	80	30	75	51	14	M8	13	0.2	1.7			
	P.C.D.102										M10	20					
T200	P.C.D.70	320.5	170	150.5	203	80	30	79	51	18	M8	15	1.1	7.9			
	P.C.D.102										M10	20					
T380	P.C.D.70										M8	15					
	P.C.D.102	397.5	208.5	189	231	80	30	91	62.5	24	M10	18.5	2.1	14			
	P.C.D.125										M12	20					
T750	P.C.D.102										M10	18.5					
	P.C.D.125	520.5	276	244.5	269	80	30	118	70	24	M12	23	4.6	24			
	P.C.D.140										M16	28					

New T-DYNAMO Dimension list

Cylinder type	Dimension (mm)											Cylinder capacity (liter/lst)	Approx. Mass (kg)			
	A	P1	P2	H3	C1	C2	f1	f3	S	MG	N					
T85S	P.C.D.70	338.5	181	157.5	168	80	30	75	51	14	M8	17	0.5	6.2		
	P.C.D.102										M10	20				
T200S	P.C.D.70	423.5	223	200.5	203	80	30	79	51	18	M8	15	1.1	10.7		
	P.C.D.102										M10	20				
T380S	P.C.D.70										M8	15				
	P.C.D.102	524.5	273.5	251	231	80	30	91	62.5	24	M10	18.5	2.1	18.9		
	P.C.D.125										M12	20				
T750S	P.C.D.102										M10	18.5				
	P.C.D.125	697.5	363	334.5	269	80	30	118	70	24	M12	23	4.6	32.4		
	P.C.D.140										M16	28				

Actuator

New ELMY 41

New MICON ELMY II 41

PMK-SRF 4K

SRJ 4J

LTKD 4L

New T-DYNAMO 7E/7F/7G

TGA 3A

TG-S 3K/3U

3C

Diaphragm 6X/6W/6Z/6A/6B

Hydraulic cylinder 3H

Manual Actuators 17/1J/2U/2I/2S/2G/2R

New T-DYNAMO Output torque curves

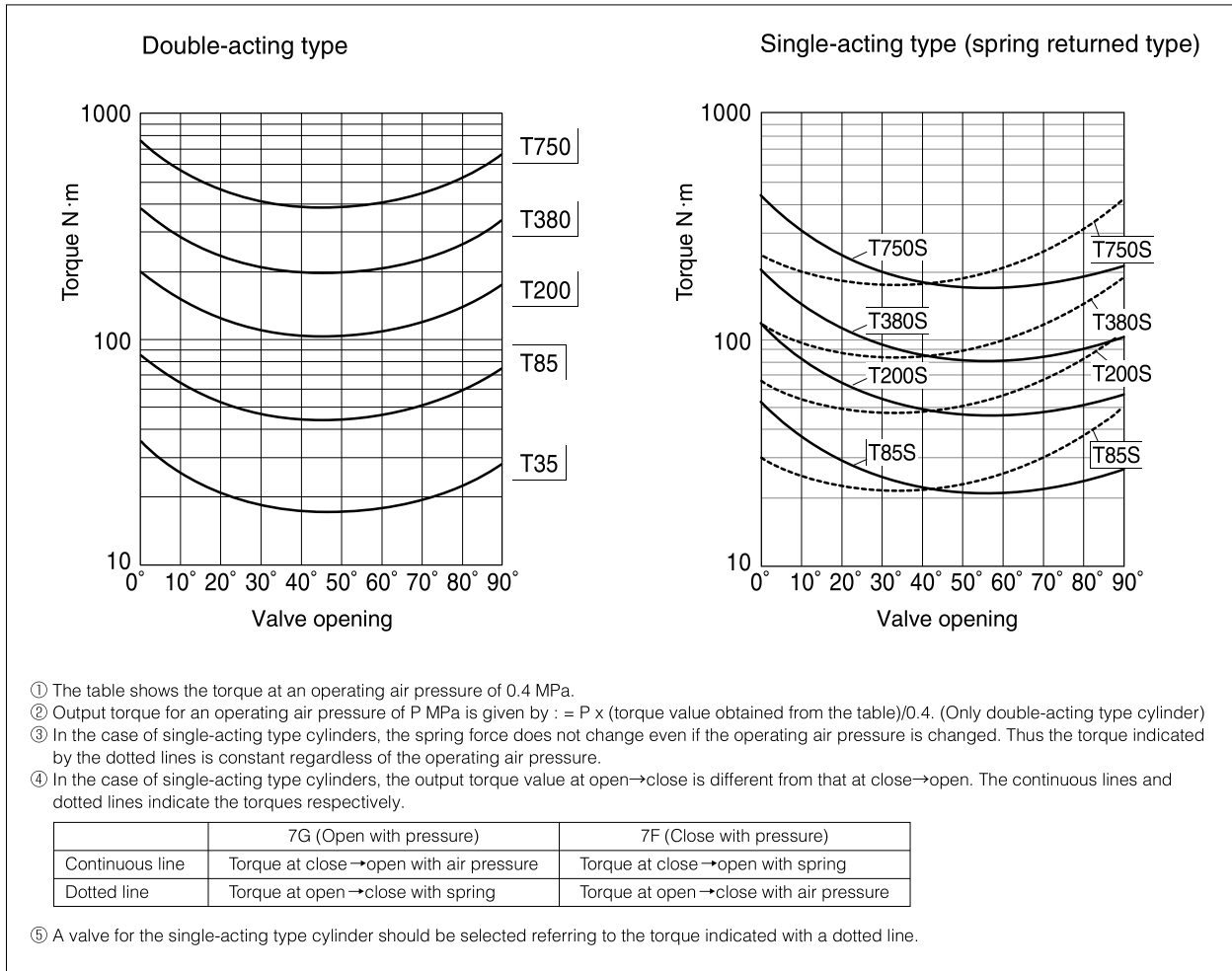

New T-DYNAMO Output torque

Double-acting type

(N·m)

Type	Supply pressure (MPa)			
	0.4	0.5	0.6	0.7
T35	35	43	52	61
T85	85	106	127	148
T200	200	250	300	350
T380	380	475	570	665
T750	750	937	1125	1312

Single-acting type (spring returned type)

(N·m)

Type	Supply pressure (MPa)								Spring	
	0.4		0.5		0.6		0.7			
	0°	90°	0°	90°	0°	90°	0°	90°	0°	90°
T85S	55	30	76	51	97	72	118	93	30	55
T200S	135	65	185	115	235	165	285	215	65	135
T380S	264	116	359	211	454	306	549	401	116	264
T750S	510	240	697	427	885	615	1072	802	240	510

New T-DYNAMO Air Consumption

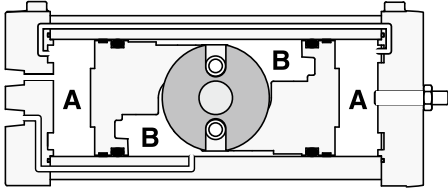

(1) Required air consumption

Double-acting type

$$VD = (A+B) \left(\frac{P+0.1013}{0.1013} \right) N$$

Single-acting type

$$VS = (B) \left(\frac{P+0.1013}{0.1013} \right) N$$

VD : Double-acting type cylinder air consumption (Nℓ)

VS : Single-acting type cylinder air consumption (Nℓ)

A,B : Cylinder capacity (ℓ)

P : Working pressure (MPa)

N : Operating frequencies in a given time (1 round trip=1)

(2) Air consumption within a unit time

Double-acting type

$$CD = \frac{VD}{t}$$

Single-acting type

$$CS = \frac{VS}{t}$$

CD : Double-acting type cylinder air consumption (Nℓ/sec)

CS : Single-acting type cylinder air consumption (Nℓ/sec)

t : Unit time (sec)

(Note) The compressor should have a larger capacity than air consumption calculated in above (1) and (2).

•Double-acting type

type	Cylinder capacity (ℓ)	
	A	B
T35	0.2	0.2
T85	0.4	0.5
T200	0.8	1.1
T380	1.8	2.1
T750	3.2	4.6

•Single-acting type

type	Cylinder capacity (ℓ)
	B
T85S	0.5
T200S	1.1
T380S	2.1
T750S	4.6

Actuator

New ELMY
41

New MICON ELMY II
41

PMK-SRF
4K

SRJ
4J

LTKD
4L

New T-DYNAMO
7E/7F/7G

TGA
3A

TG-S
3K/3U

3C

Diaphragm
6X/6W/6Z/6A/6B

Hydraulic cylinder
3H

Manual Actuators
17/1J/2U/2I/2S/2G/2R

New T-DYNAMO Expanded view of component T35 to T750 (double-acting type)

Note: The parts numbers marked with □ indicate "O-ring set".
Please exchange all the parts included in the set.

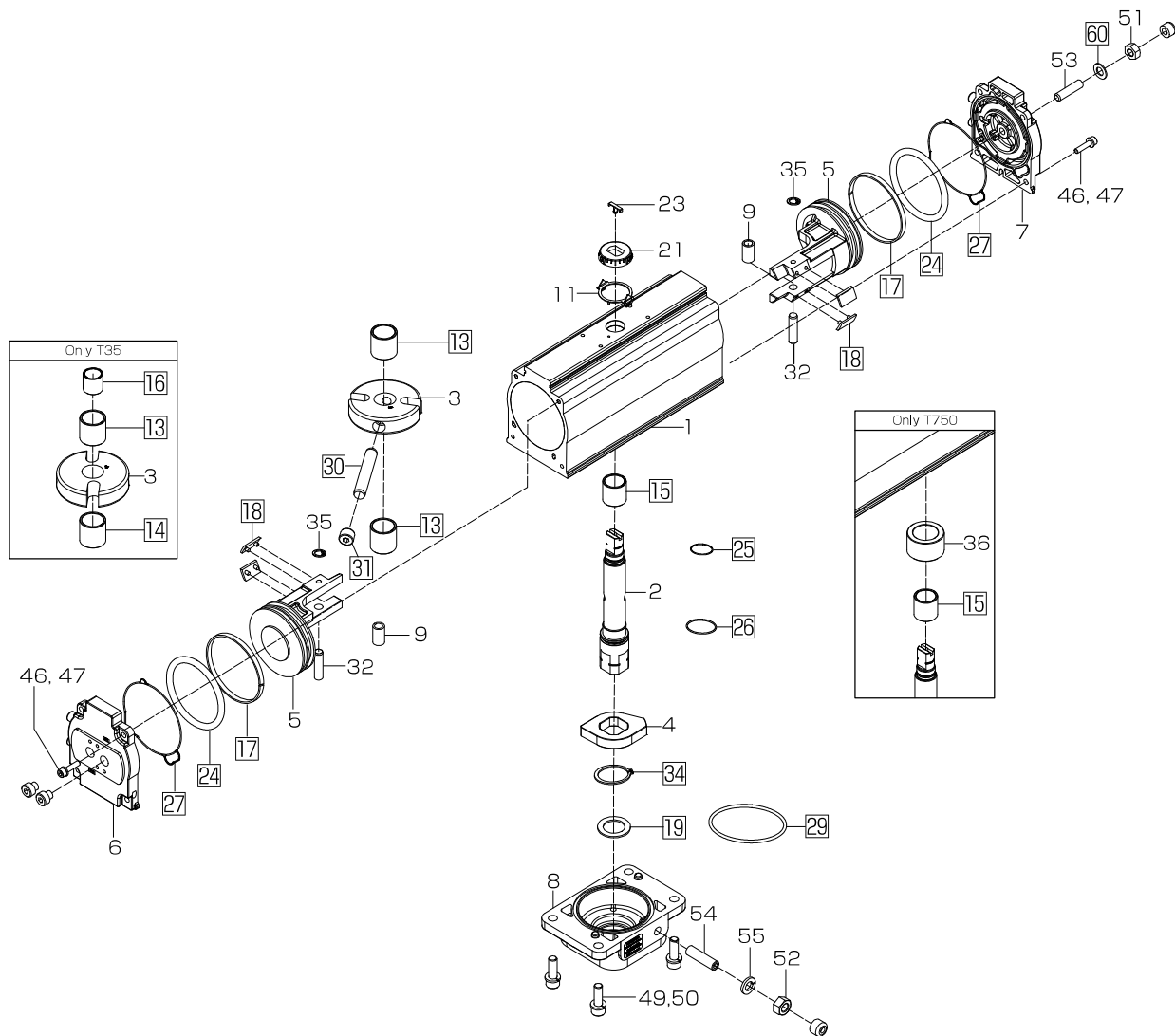

New T-DYNAMO Parts list T35 to T750 (double-acting type)

■ Double-acting type

No.	Description	Q'ty	Remarks
1	Case	1	
2	Shaft	1	
3	Yoke	1	
4	Stopper	1	
5	Piston	2	
6	Cover 1	1	
7	Cover 2	1	
8	Base plate	1	
9	Bearing	2	
11	Indicator plate	1	
★ 13	Bearing 1	2	T35:1pc
★ 14	Bearing 2	1	Only T35
★ 15	Bearing 3	1	
★ 16	Bearing 4	1	Only T35
★ 17	Wear ring	2	
★ 18	Piston support	4	
★ 19	Thrust plate	1	
21	Position indicator	1	
23	Slit cover	1	
★ 24	Piston packing	2	
★ 25	O-ring (Upper Side)	1	
★ 26	O-ring (Lower Side)	1	
★ 27	Cover packing	2	
★ 29	O-ring (base plate)	1	
★ 30	Connecting pin	1	
★ 31	Plug	1	
32	Parallel pin	2	
★ 34	C-retainer (lower shaft)	1	Only T85~T750
35	C-retainer (piston)	2	Only T85~T750
36	Bearing housing	1	Only T750
46	Spring washer (cover 1,2)	8	
47	Hexagon bolt (cover: double-acting)	8	
49	Hexagon bolt (base plate)	4	T35:2pcs
50	Spring washer (base plate)	4	T35:2pcs
51	Hexagon stop screw	1	
52	Hexagon stop screw	1	
53	Hexagon socket set screw (open-side)	1	
54	Hexagon socket set screw (close-side)	1	
55	Spring washer (close-side stopper)	1	
★ 60	Sealing washer	1	

Note: Recommended maintenance parts are indicated by "★" before the part number.
To order a set of recommended maintenance parts, please specify "O-ring set".

Actuator
New ELMY 41
New MICON ELMY II 41
PMK-SRF 4K
SRJ 4J
LTKD 4L
New T-DYNAMO 7E/7F/7G
TGA 3A
TG-S 3K/3U
3C
Diaphragm 6X/6W/6Z/6A/6B
Hydraulic cylinder 3H
Manual Actuators 1T/1J/2U/2I/2S/2G/2R

New T-DYNAMO Expanded view of component T85S to T750S (single-acting type)

Note: The parts numbers marked with □ indicate "O-ring set".
Please exchange all the parts included in the set.

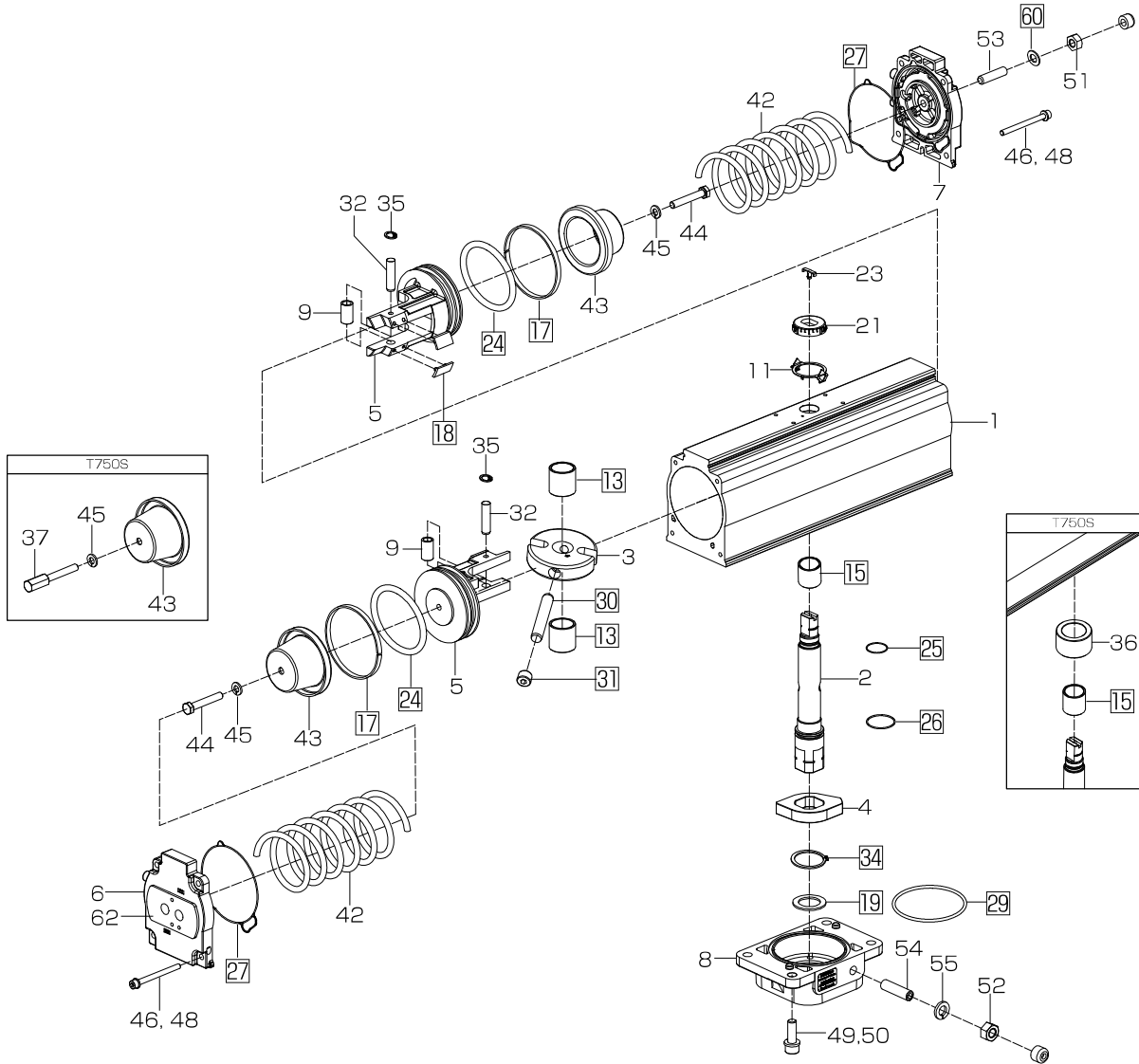

New T-DYNAMO Expanded view of component T85S to T750S (single-acting type)

■ Single-acting type

No.	Description	Q'ty	Remarks
1	Case	1	
2	Shaft	1	
3	Yoke	1	
4	Stopper	1	
5	Piston	2	
6	Cover 1	1	
7	Cover 2	1	
8	Base plate	1	
9	Bearing	2	
11	Indicator plate	1	
★ 13	Bearing 1 (shaft-piston)	2	
★ 15	Bearing 3 (lower shaft)	1	
★ 17	Wear ring	2	
★ 18	Piston support	4	
★ 19	Thrust plate	1	
21	Position indicator	1	
23	Slit cover	1	
★ 24	Piston packing	2	
★ 25	O-ring (upper)	1	
★ 26	O-ring (lower)	1	
★ 27	Cover packing	2	
★ 29	O-ring (base plate)	1	
★ 30	Connecting pin	1	
★ 31	Plug	1	
32	Parallel pin	2	
★ 34	C-retainer (lower shaft)	1	
35	C-retainer (piston)	2	
36	Bearing housing	1	Only T750S
37	Stopper bolt	1	Only T750S
42	Spring	2	
43	Spring guide	2	
44	Hexagon bolt (spring guide)	2	
45	Spring washer (spring guide)	2	
46	Spring washer (cover 1,2)	8	
48	Hexagon socket bolt (cover 1,2)	8	
49	Hexagon socket bolt (base plate)	4	
50	Spring washer (base plate)	4	
51	Hexagon nut (cover 2)	1	
52	Hexagon nut (base plate)	1	
53	Hexagon socket set screw (cover 2)	1	
54	Hexagon socket set screw (base plate)	1	
55	Spring washer (base plate)	1	
★ 60	Sealing washer (cover 2)	1	
62	Hexagon socket tapered plug (cover 1)	1	

Note: Recommended maintenance parts are indicated by "★" before the part number.
To order a set of recommended maintenance parts, please specify "O-ring set".

Actuator
New ELMY 41
New MICON ELMY II 41
PMK-SRF 4K
SRJ 4J
LTKD 4L
New T-DYNAMO 7E/7F/7G
TGA 3A
TG-S 3K/3U
3C
Diaphragm 6X/6W/6Z/6A/6B
Hydraulic cylinder 3H
Manual Actuators 17/1J/2U/2I/2S/2G/2R

New T-DYNAMO Solenoid valves

Purpose

The purpose of a solenoid valve is to use electrical signals to remotely change the air flow to operate the valves.

Standard specifications

Type	Five-port/2-position non explosion-proof solenoid valve (single solenoid)	Five-port/2-position non explosion-proof solenoid valve (double solenoid)	Five-port/2-position explosion-proof solenoid valve (single solenoid)	Five-port/2-position explosion-proof solenoid valve (double solenoid)
Item	PCS2406-K090-Z03-132-**-**	PCD2406-K090-Z04-120-**-**	MK15G-8-**-DMI	MK15DG-8-**-DMI
Manufacturer	TAIYO	TAIYO	Kaneko	Kaneko
JIS symbol				
Applicable cylinder type	T35 to T750/T85S to T750S	T35 to T750/T85S to T750S	T35 to T750/T85S to T750S	T35 to T750/T85S to T750S
Mounting method	Direct mounting	Direct mounting	Direct mounting	Direct mounting
Air connection port size	Rc1/4 (IN, EXH)	Rc1/4 (IN, EXH)	Rc1/4 (IN, OUT, EXH)	Rc1/4 (IN, OUT, EXH)
Effective sectional area	10mm ²	10mm ²	20mm ²	20mm ²
Rated voltage	AC100V/110V 50/60Hz AC200V/220V 50/60Hz DC24V	AC100V/110V 50/60Hz AC200V/220V 50/60Hz DC24V	AC100V 50/60Hz AC110V/200V 50Hz AC220V 60Hz DC24, 100, 110, 125V	AC100V 50/60Hz AC100V, 200V 50Hz AC220V 60Hz DC24, 100, 110, 125V
Class of insulation	—	—	d2G4	d2G4
Wiring method	Conduit terminal	Conduit terminal	Conduit terminal	Conduit terminal
Conduit entry	G1/2	G1/2	G1/2	G1/2
Manual operating	Non lock bush type	Non lock bush type	Manual button lock type	Manual button lock type
Operating temperature	—5 to 50 degrees C	—5 to 50 degrees C	—20 to 60 degrees C	—20 to 60 degrees C
Weight	0.2kg	0.27kg	1.2kg	1.7kg

Remark: The above are standard TOMOE-compatible solenoid valves. It is also possible to install solenoid valves other than those listed above such as a double solenoid or 3-port solenoid valve. For details, please consult us.

New T-DYNAMO Filter regulators (Pressure reducer with filter)

Purpose

Filter regulators are used to eliminate oil, water, and dust from the operating air in order to protect pneumatic accessories (solenoid valve and cylinder, etc.) and to keep operating pressure at an adequate and constant level (about 4 to 5 K).

Standard specifications

Type	P31EA22EMMBNPN
Manufacturer	TAIYO
JIS symbol	
Applicable cylinder type	T35 to T750/T85S to T750S
Set pressure range	0.03 to 0.85MPa
Pressure gauge connection port	Rc1/8
Operating temperature	—5 to 60 degrees C
Air connection port size	Rc1/4
Filtration	5μm
Attachment	Direct mounting
Option	—
Weight	0.19kg

Remark: The above are standard TOMOE-compatible filter regulators. It is also possible to install filter regulators other than those listed above. For details, please consult us.

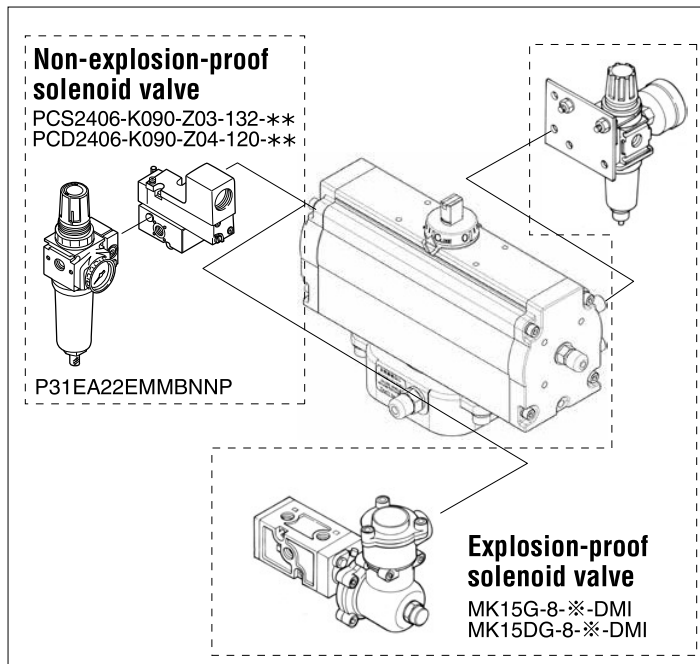

Actuator

New ELMY 41
New MICON ELMY II 41
PMK-SRF 4K
SRJ 4J
LTKD 4L
New T-DYNAMO 7E/7F/7G
TGA 3A
TG-S 3K/3U
3C
Diaphragm 6X/6W/6Z/6A/6B
Hydraulic cylinder 3H
Manual Actuators 17/1J/2U/2I/2S/2G/2R

New T-DYNAMO Limit switches

■ Purpose

Limit switches are used to convert the valve position (full close, full open, half open) into electric signals for lamp indication at a remote location.

■ Standard specifications

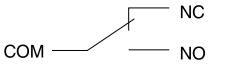
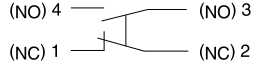
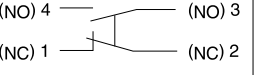
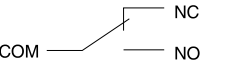
Type	TMS-BOX	1LS1-J WLCA2	1LX-7001	VCX-7003
Manufacturer	Tomoe	Azbil (1LS1-J) OMRON (WLCA2)	Azbil	Azbil
Circuit	Monopolar double-throw (1C, SPDT) X2 	Bipolar double interruption (1A1B, 2CKT-DB) 	Bipolar double interruption (1A1B, 2CKT-DB) 	Monopolar double-throw (1C, SPDT) X2 
Actuator	Hinge roller lever type	Roller lever type	Roller lever type	Adjustable roller lever type
Class of insulation	IP67 (Option: ExdⅡBT6)	IP67	IP67, Exde IIC T6	IP67, Exde IIC T6
Rated voltage (resistance load)	Standard	Micro load specifications		
	AC250V-1.6A DC125V-0.6A	AC125V-0.1A DC30V-0.1A	AC125V-10A AC250V-10A AC480V-10A DC125V-0.8A DC250V-0.4A	AC125V-5A AC250V-5A DC125V-0.8A DC250V-0.4A
Minimum applicable load (reference value)	DC30V 100mA	DC5V 1mA	DC24V 10mA(1LS1-J) DC5V 160mA(WLCA2)	DC24V 10mA
Operating temperature	-10 to 80 degrees C		1LS1-J: -10~70°C WLCA2: -10~80°C	-10 to 60 degrees C
Conduit entry	2-G1/2	G1/2	G1/2	G3/4
Option	—	Heat, cold and corrosion resistant	Hydrogen anti-explosion (1LX7001)	Waterproof (VCL-5003)
Contacts	Switch detection with one (2 switches inside)	On or off detection with one Two for both on and off detection	On or off detection with one Two for both on and off detection	Switch detection with one (2 switches inside)
Weight	0.98kg	0.28kg	0.74kg	0.77kg

Remark: The above are standard TOMOE-compatible limit switches. It is also possible to install limit switches other than those listed above. For details, please consult us. Since the rated load of the TMS-BOX micro load specification is smaller than that of the standard specification, a failure may occur if a current exceeding the rating is applied.

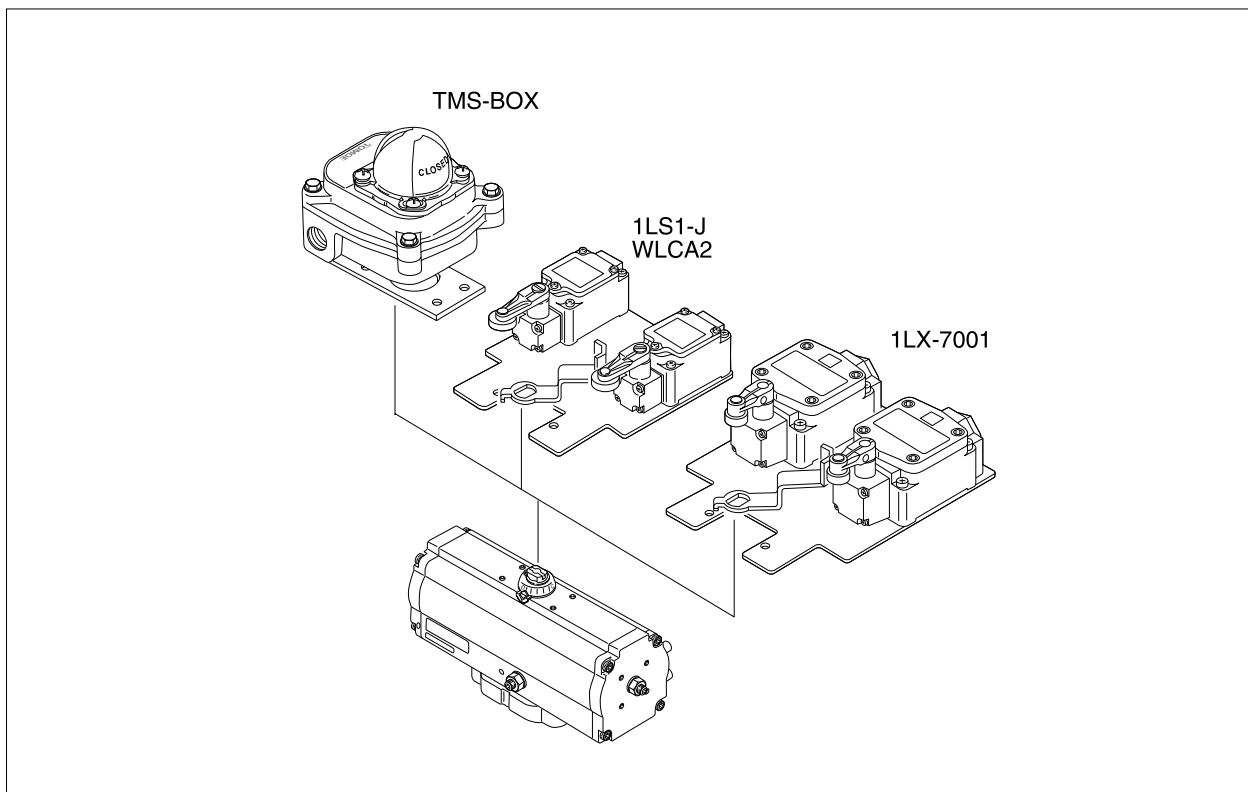

New T-DYNAMO Proximity switches

■ Purpose

Proximity switches are used to convert the valve position (full close, full open, half open) into electric signals for lamp indication at a remote location.

■ Standard specifications

Product	M18 shielded type (Can be embedded in metal.)	Direct-mounting proximity switch
Type	E2E-X7D1-N	IND2004DARKG
Manufacturer	OMRON	efector
With power source	DC 2-wire system	DC 2-wire system
Motion mode	NO	NO
Detecting distance	0 to 5.6mm	4mm±10%
Object to be detected	Magnetic metal (stainless steel possible)	Dedicated target
Power source voltage	DC12 to 24V	DC10 to 36V
Current consumption	3 to 100mA	min 4mA
Class of insulation	IP67	IP67
Operating temperature	-25 to 70 degrees C	-25 to 80 degrees C
Connection	Cord draw type (2m)	Cord draw type (2m)
Contacts	On or off detection with one Two for both on and off detection	2-point switch detection possible with a single unit
Weight	0.43 kg (including mounting plate): 1 piece	0.23 kg (including mounting plate): 1 piece

Remark: The above are standard TOMOE-compatible proximity switches. It is also possible to install limit switches other than those listed above such as a DC 3-wire, AC 2-wire, AC/DC 2-wire or connector-type proximity switch. For details, please consult us.

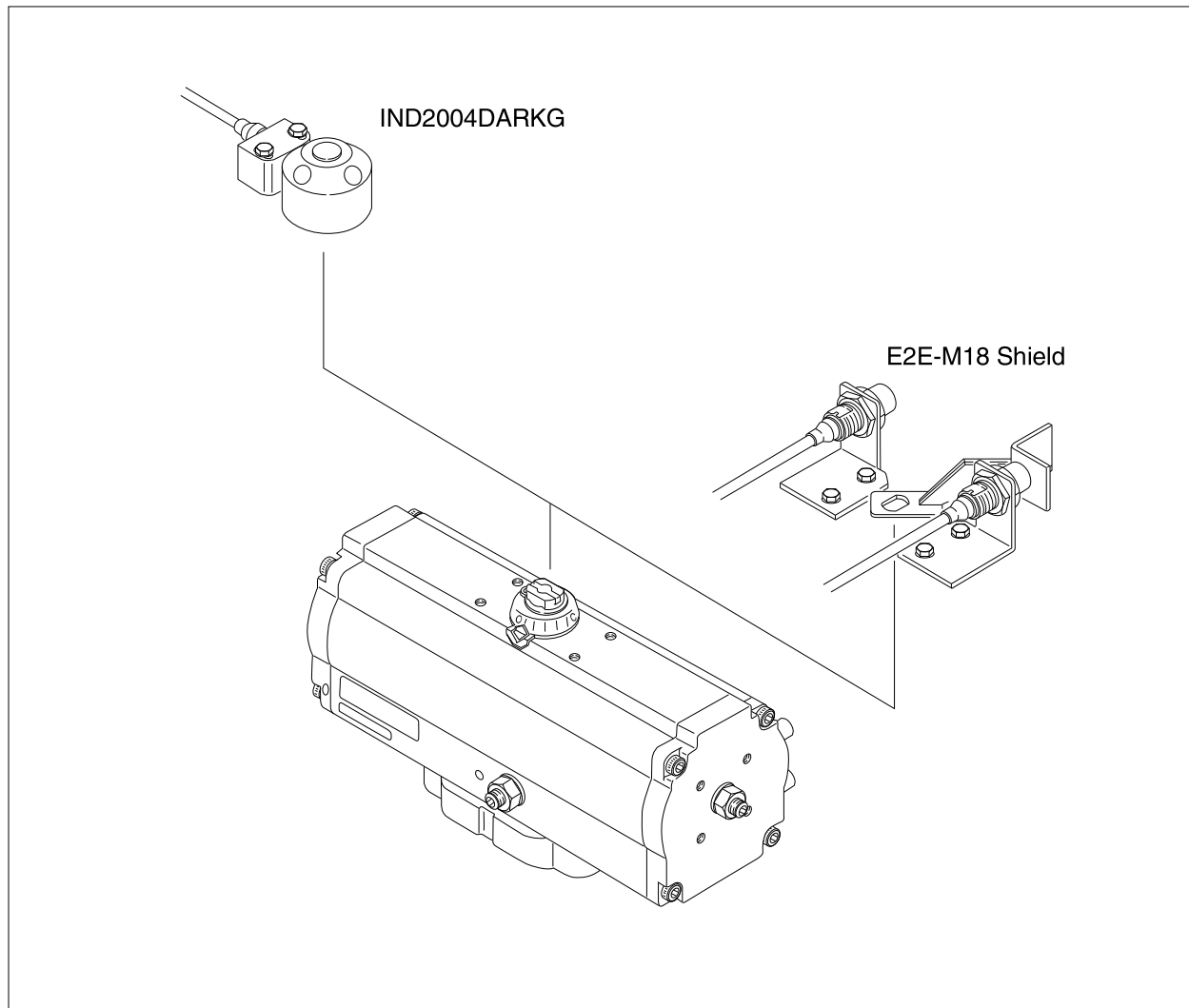

Actuator
New ELMY 4I
New MICON ELMY II 4I
PMK-SRF 4K
SRJ 4J
LTKD 4L
New T-DYNAMO 7E/7F/7G
TGA 3A
TG-S 3K/3U
3C
Diaphragm 6X/6W/6Z/6A/6B
Hydraulic cylinder 3H
Manual Actuators 17/1J/2U/2I/2S/2G/2R

New T-DYNAMO Positioners

■ Purpose

A positioners are used for quick and accurate control of the valve opening angle with pneumatic signals or 4-20mA DC input signals from a control room or controller unit.

■ Standard specifications

Type	Electro-Pneumatic, analog TCE2000	Electro-Pneumatic, analog TP8100	Pneumatic-Pneumatic IP5100
Manufacturer	Tomoe	Tomoe	SMC
Input signal	4 to 20mA	4 to 20mA	0.02 to 0.1MPa
Resistance	250Ω (4 to 20mADC)	235±15Ω (4 to 20mADC)	—
Supply air	0.14 to 0.7MPa	0.14 to 0.7MPa	0.14 to 0.7MPa
Output flow rate	180L/min.(ANR) or more (SUP=0.4MPa)	200L/min.(ANR) or more (SUP=0.4MPa)	200L/min.(ANR) or more (SUP=0.4MPa)
Air consumption	Within 11L/min.(ANR) (SUP=0.4MPa)	Within 11L/min.(ANR) (SUP=0.4MPa)	Within 11L/min.(ANR) (SUP=0.4MPa)
Operating temperature	-20 to 83 degrees C (Non explosion-proof) -20 to 60degrees C (Explosion-proof type d2G4)	-20 to 8 degrees C (Non explosion-proof) -20 to 60 degrees C (Explosion-proof)	-20 to 80 degrees C
Class of insulation	IP65, ExdIIBT6X	IP65, ExdIIBT5	—
Air connection port size	Rc1/4	Rc1/4	Rc1/4
Conduit entry	2-G1/2	2-G1/2	—
Sensitivity	Within 0.5%FS	Within 0.5%FS	Within 0.5%FS
Linearity	Within ±1.5%FS	Within ±2%FS	Within ±2%FS
Hysterisis	Within 1%FS	Within 1%FS	Within 1%FS
Option	—	—	—
Weight	2.3kg	2.6kg	1.2kg

Remark: The above are standard TOMOE-compatible positioners. It is also possible to install positioners other than those listed above. For details, please consult us.

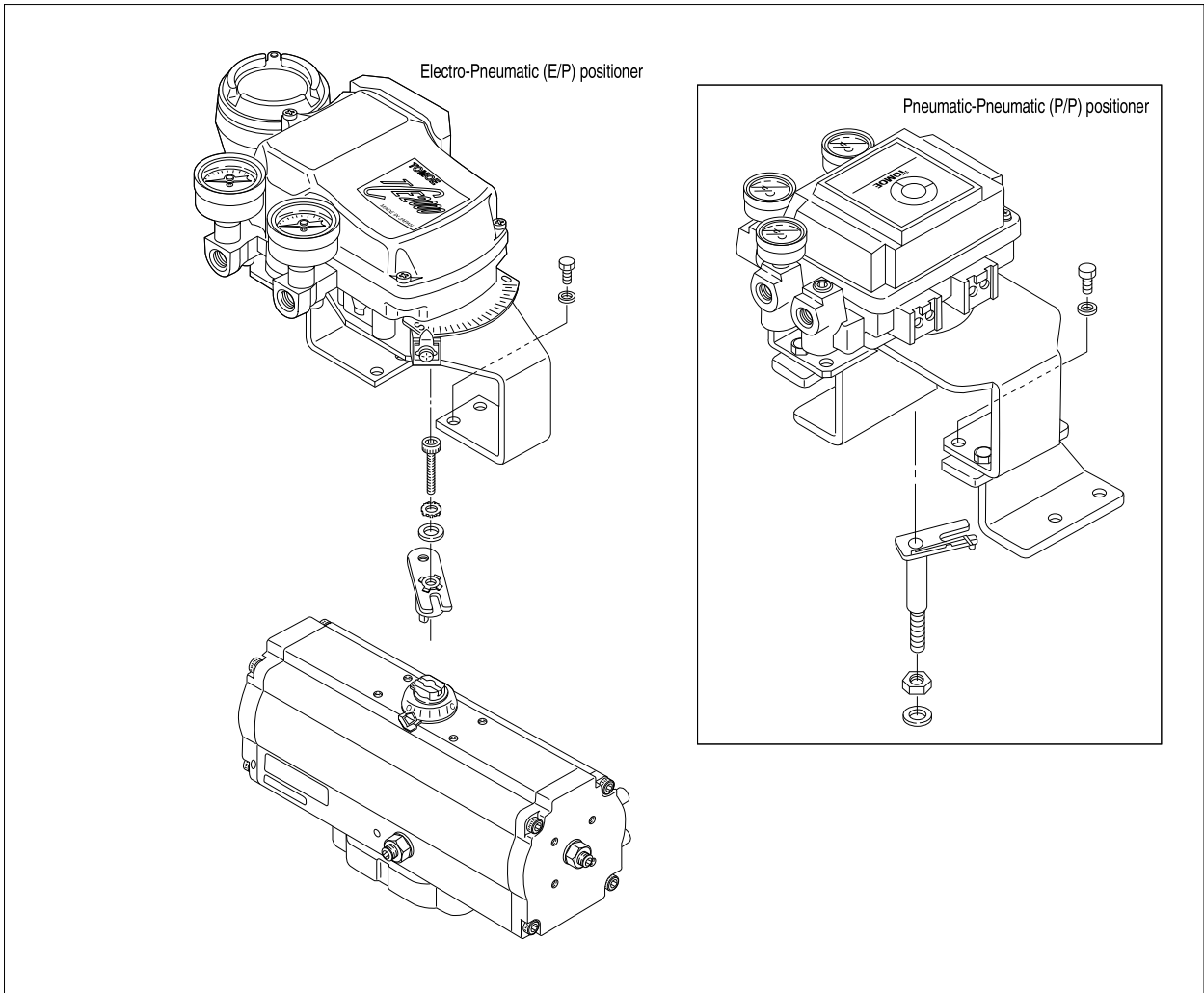

New T-DYNAMO Manual operation unit

■ Purpose

The operation unit is for manual operation of the pneumatic cylinder when air supply fails.

■ Standard specifications

	Function	Type	Applicable cylinder	Manual Operation Procedure	Remarks
1	Manual lever	Lever	T35, T85, T200, T380 (Double-acting)	(1) Open the bypass valve. (2) Turn the center axis using a spanner.	(1) Never use for any single acting type cylinder. (2) Do not input signal to the solenoid valve or positioner during operation.
2	Side handle	Screw handle	T85S, T200S, T380S, T750S (Single-acting)	(1) Open the bypass valve. (2) Turn the handwheel in accordance with the direction indicated on the nameplate located in the middle of the manual screw handle to open and close the valve.	(1) Do not input signal to the solenoid valve or positioner during operation. (2) Restore the valve angle in the position air supply shutted off when restarting the automatic operation.
3	Manual gear unit	Worm gear	T200, T380, T750 (Double-acting)	(1) Remove residual pressure from the cylinder. (2) Turn the handwheel.	(1) Do not input signal to the solenoid valve or positioner during operation. (2) Restore the valve angle in the position air supply shutted off when restarting the automatic operation.

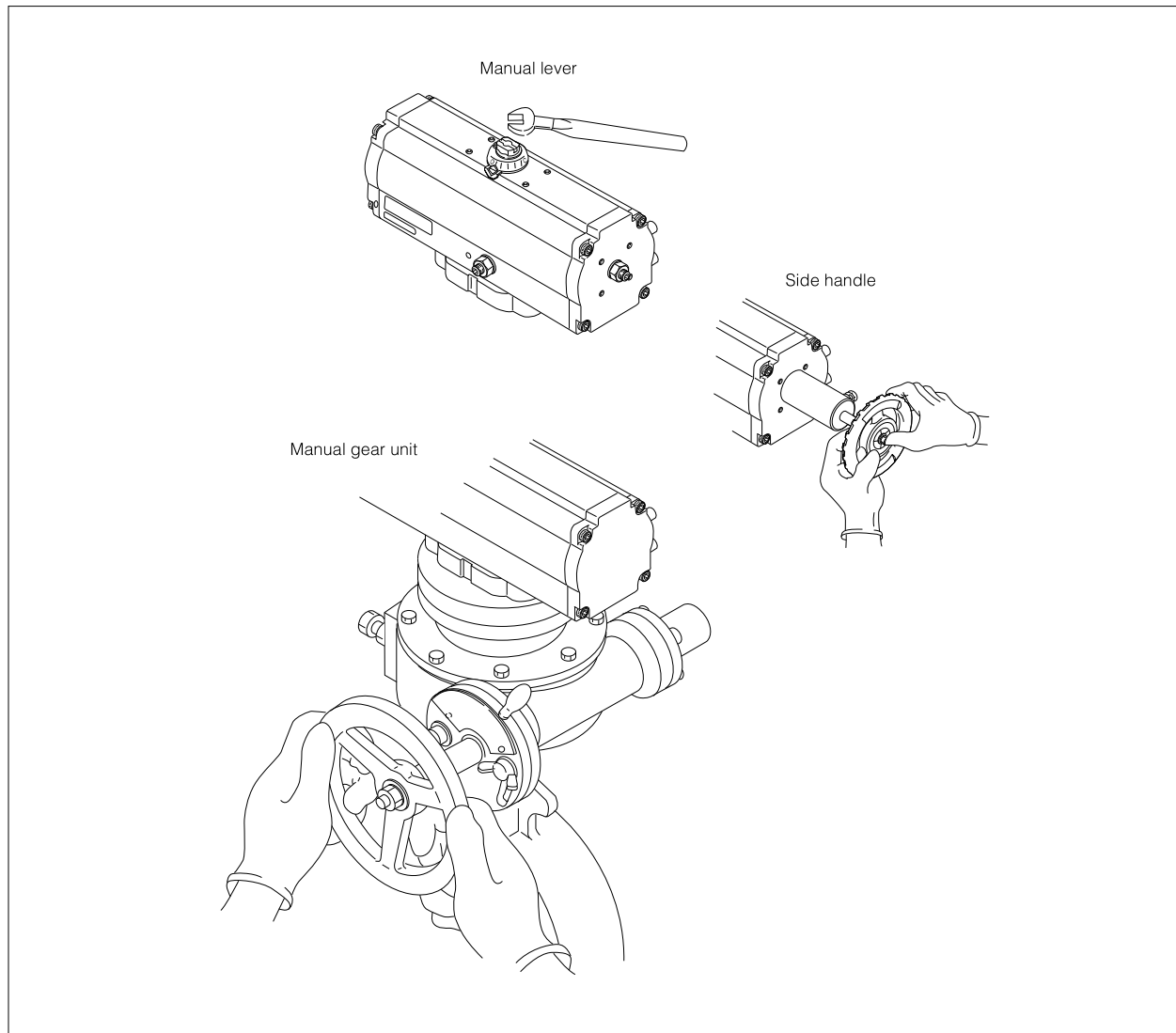

Actuator
New ELMY 41
New MICON ELMY II 41
PMK-SRF 4K
SRJ 4J
LTKD 4L
New T-DYNAMO 7E/7F/7G
TGA 3A
TG-S 3K/3U
3C
Diaphragm 6X/6W/6Z/6A/6B
Hydraulic cylinder 3H
Manual Actuators 17/1J/2U/2I/2S/2G/2R

New T-DYNAMO Free-angle adjuster

■ Purpose

Free-angle adjuster enables to set open/close angle depending on users' demand.

■ Standard specifications

Function	Type	Applicable cylinder	Remarks
Free-angle adjuster	Side adjust screw	T35 to T750/T85S to T750S (Air to open)	Remove the cylinder cover, loosen the lock nut and insert the bolt to adjust the stroke angle. Tighten the lock nut and attach the cylinder cover in position.

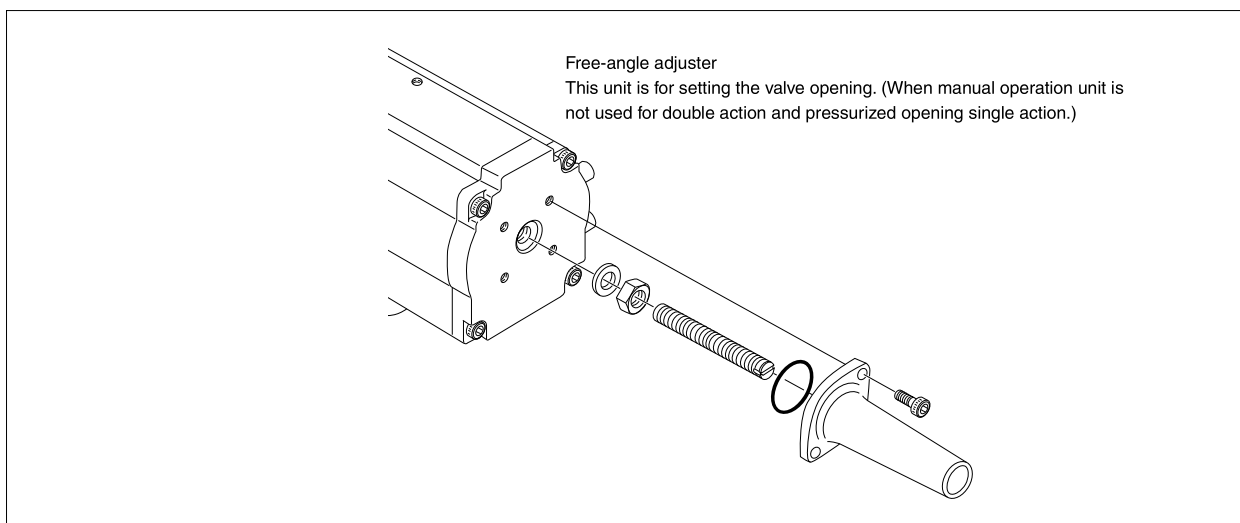

New T-DYNAMO Speed controllers

■ Purpose

For double-acting cylinders, the speed controller is used as meter out (exhaust throttle) and for single-acting cylinders, it is used as meter in (suction throttle).

■ Standard specifications

Type	MV-2-Z03-017	SP-K017-Z03-006
Manufacturer	TAIYO	TAIYO
JIS symbol		
Applicable cylinder type	With PCS 2406-K090-Z132 solenoid valve mounted	Other than indicated at left
Function	With silencer	—
Needle revolution	10 rotations	11 rotations
Adjustable range	5 to 15 secs.	5 to 15 secs.
Air connection port size	—	Rc1/4
Attachement	Screw into solenoid valve exhaust port (Rc 1/4)	Install to cylinder
Weight	0.06kg	0.095kg

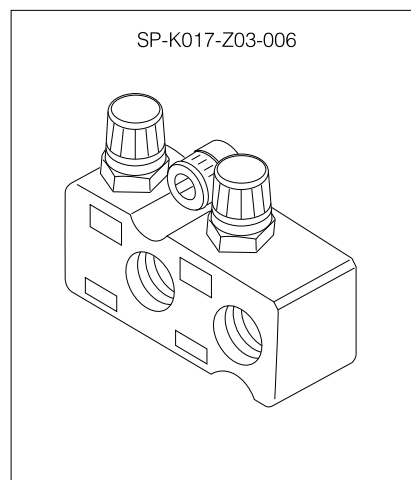

Remark: The above are standard TOMOE-compatible speed controllers. It is also possible to install speed controllers other than those listed above. For details, please consult us.



Remark: In case of Single-action (spring open, type 7F), speed controller type is SP-K017-Z12-003-F.

New T-DYNAMO Silencers

Purpose

Silencers eliminate noise at the exhaust ports on various kinds of pneumatic accessories.

Standard specifications

Type	AN10-C06	AN20-02
Manufacturer	SMC	SMC
JIS symbol		
Applicable cylinder type	T35 to T750/T85S to T750S	T35 to T750/T85S to T750S
Effect of muffing	25dB (A)	30dB (A)
Operating temperature	5 to 60 degrees C	5 to 60 degrees C
Port size	φ6	Rc1/4
Attachment	Install to exhaust port together with one-touch pipe coupler.	Screw into exhaust port.
Weight	0.02kg	0.02kg

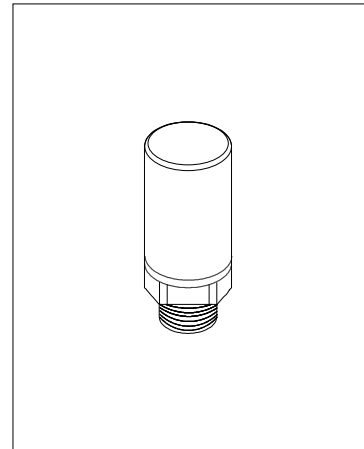

Remark: The above are standard TOMOE-compatible silencers. It is also possible to install silencers other than those listed above. For details, please consult us.

New T-DYNAMO Lock-up valves

Purpose

When air supply fails, the lock-up valve automatically stops the line until pressure is restored and keeps the operating unit of the cylinder at the stay-put position.

Standard specifications

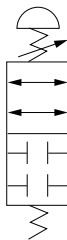
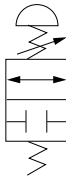
Type	IL211-02	IL201-02
Manufacturer	SMC	SMC
JIS symbol		
Applicable cylinder type	T35 to T750	T85S to T750S
Effective sectional area	17mm ²	17mm ²
Operating temperature	-5 to 60 degrees C	-5 to 60 degrees C
Air connection port size	Rc1/4	Rc1/4
Signal pressure connection port	Rc1/4	Rc1/4
Weight	0.64kg	0.43kg

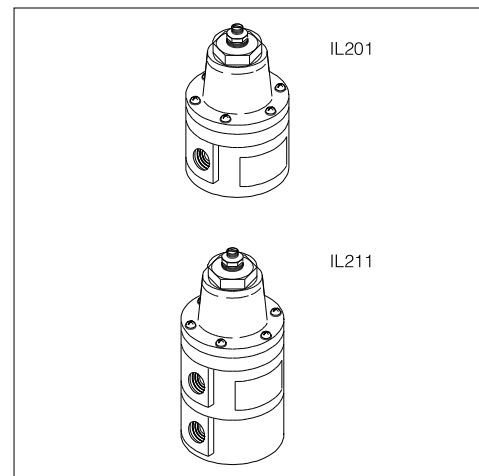

Remark: The above are standard TOMOE-compatible lock-up valves. It is also possible to install lock-up valves other than those listed above. For details, please consult us.

Actuator
New ELMY 4I
New MICON ELMY II 4I
PMK-SRF 4K
SRJ 4J
LTKD 4L
New T-DYNAMO 7E/7F/7G
TGA 3A
TG-S 3K/3U
3C
Diaphragm 6X/6W/6Z/6A/6B
Hydraulic cylinder 3H
Manual Actuators 17/1J/2U/2I/2S/2G/2R

Standard and semi-standard accessories and their use

Example of standard air circuit for on/off operation (double-acting type)

Shown below are standard circuits to open and close a butterfly valve driven by a double-acting air cylinder while transmitting electrical signals from a remote control room. Switching of the flow of operation air is performed by the solenoid valve, and detection of the open/close position of the valve is performed by a limit switch, with feedback of the electrical signals to the control room.

1 Butterfly valve opens when solenoid valve is energized.

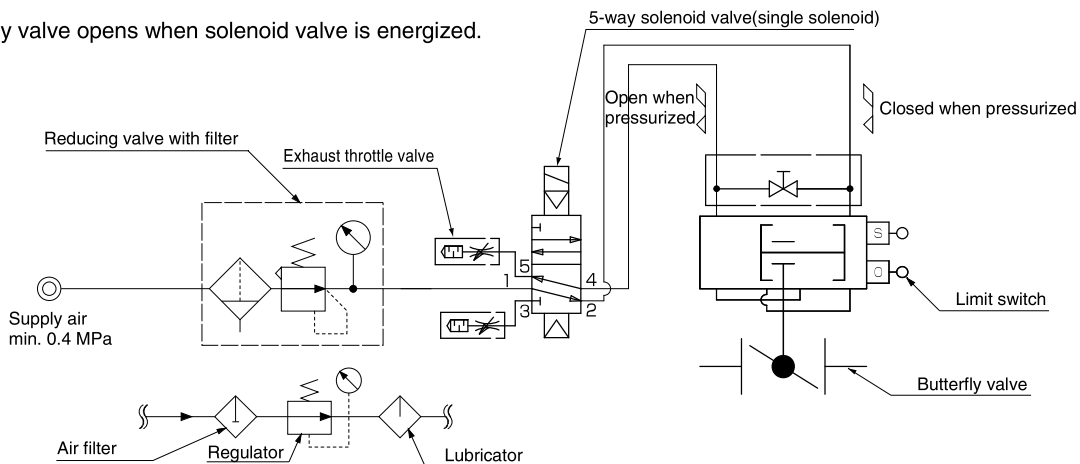

2 Butterfly valve closes when solenoid valve is energized.

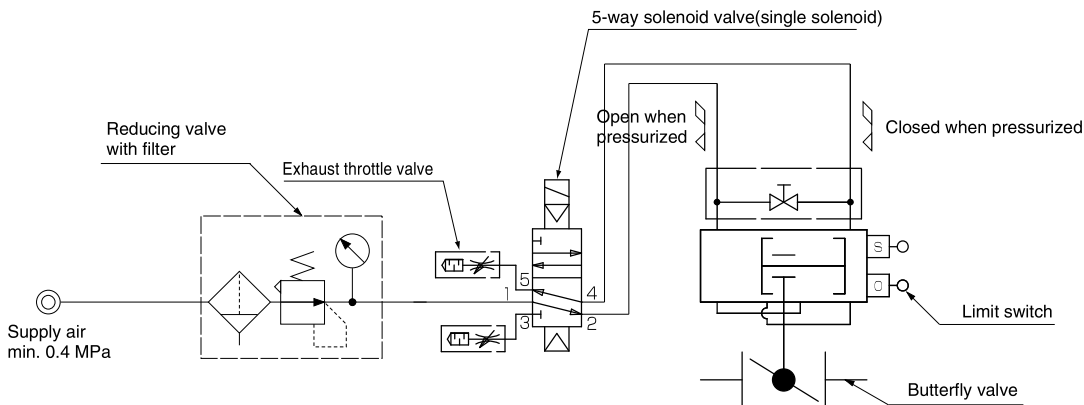

3 Butterfly valve closes when SOL.1 is energized.
Butterfly valve opens when SOL.2 is energized.

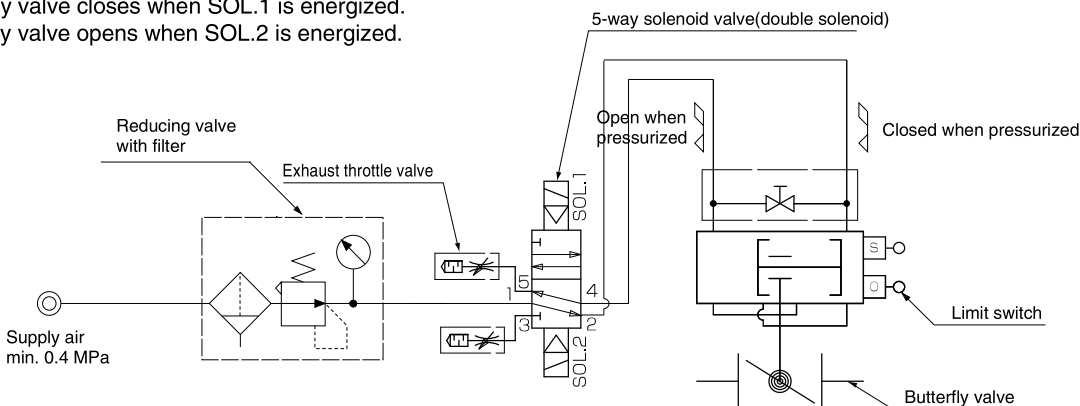

→Once SOL.1 is energized, the condition is maintained even after it is de-energized unless SOL.2 is energized.

Example of standard air circuit for control operation (double-acting type)

Shown below are examples of standard circuits in which a P/P or E/P positioner is attached to the butterfly valve driven by a double-acting pneumatic cylinder to give instruction signals from a remote control room to the positioner. This adjusts the valve opening exactly and quickly in proportion to the signals, and also detects the open/close position of the valve by a limit switch which sends feedback of the electrical signals to the control room.

4 Direct action

- Butterfly valve closes when signal increases.
- Butterfly valve opens when signal decreases.

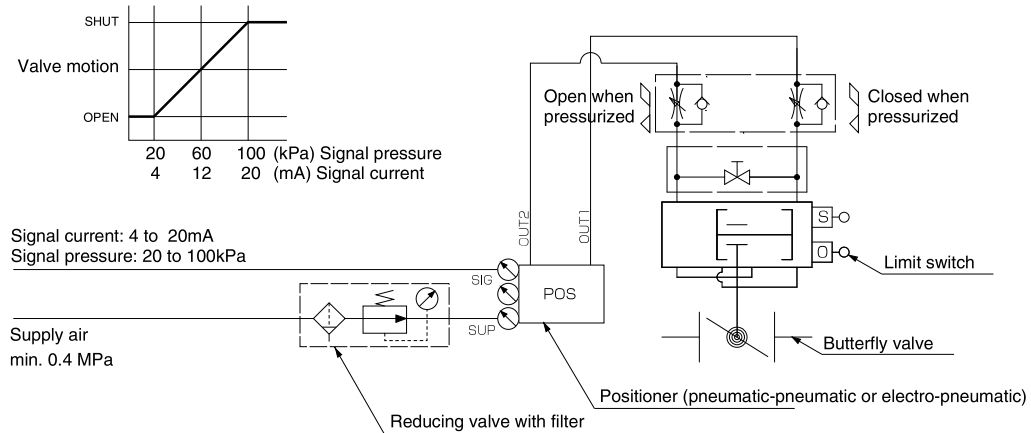

→The butterfly valve opens fully when the input signal goes off under a state of assured air supply.

5 Reverse action

- Butterfly valve opens when signal increases.
- Butterfly valve closes when signal decreases.

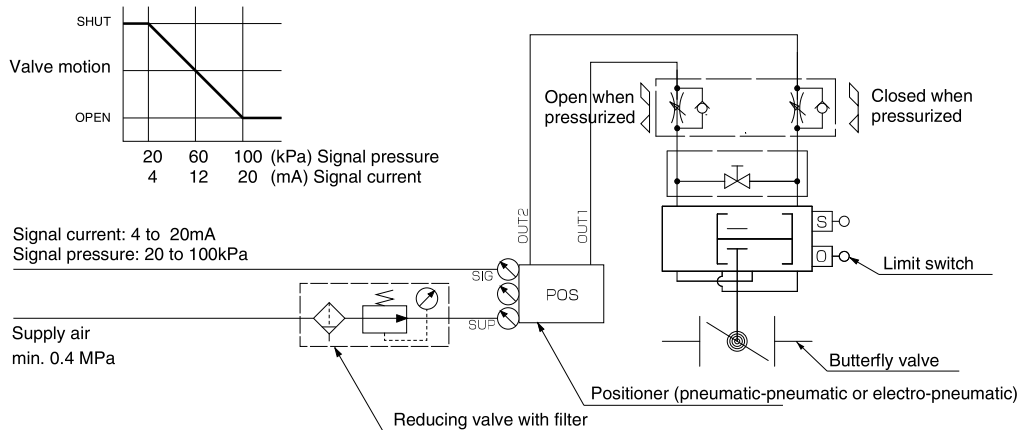

→The butterfly valve closes fully when input signal goes off under a state of assured air supply.

Actuator
New ELMY 41
New MICON ELMY II 41
PMK-SRF 4K
SRJ 4J
LTKD 4L
New T-DYNAMO 7E/7F/7G
TGA 3A
TG-S 3K/3U
3C
Diaphragm 6X/6W/6Z/6A/6B
Hydraulic cylinder 3H
Manual Actuators 17/1J/2U/2I/2S/2G/2R

Example of standard air circuit for on/off operation (single-acting type)

Shown below are examples of standard circuits to operate the valve automatically to the safe side of open or close when the operating air supply or power supply fails in the middle of operation.

- 1** Butterfly valve closes when air supply falls.
 (Opened by pressure when solenoid valve is energized.)
 Butterfly valve closes when power supply falls.
 (Opened by pressure when solenoid valve is energized.)

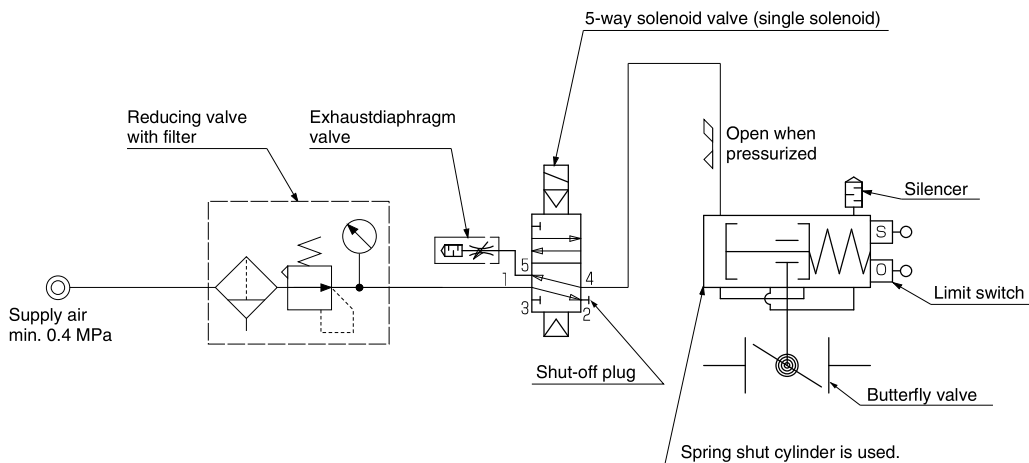

- 2** Butterfly valve opens when power supply falls.
 (Closed by pressure when solenoid valve is energized.)
 Butterfly valve opens when air supply falls.
 (Closed by pressure when solenoid valve is energized.)

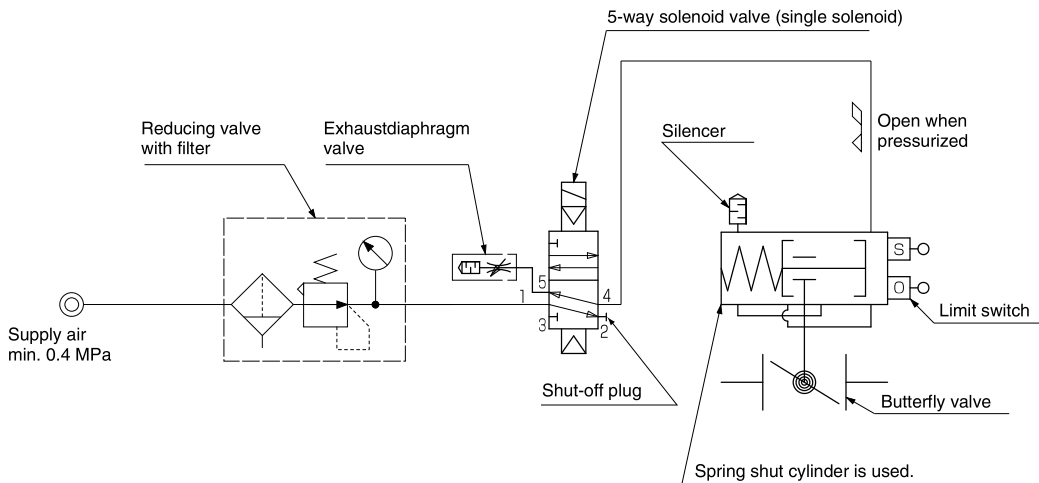

Example of standard air circuit for control operation (single-acting type)

Shown below are examples of standard circuits in which the P/P or E/P positioner is attached to the butterfly valve driven by a single-acting pneumatic cylinder to adjust valve opening exactly and quickly in proportion to the signals transmitted by a local controller or from a remote control room. This will also detect the open/close position of the valve by a limit switch which sends feedback of the electric signals to the control room. When the operating air supply or power supply fails, the valve is automatically operated to the safe side of open or close.

3 Direct action

Butterfly valve closes when signal increases.
Butterfly valve opens when signal decreases.

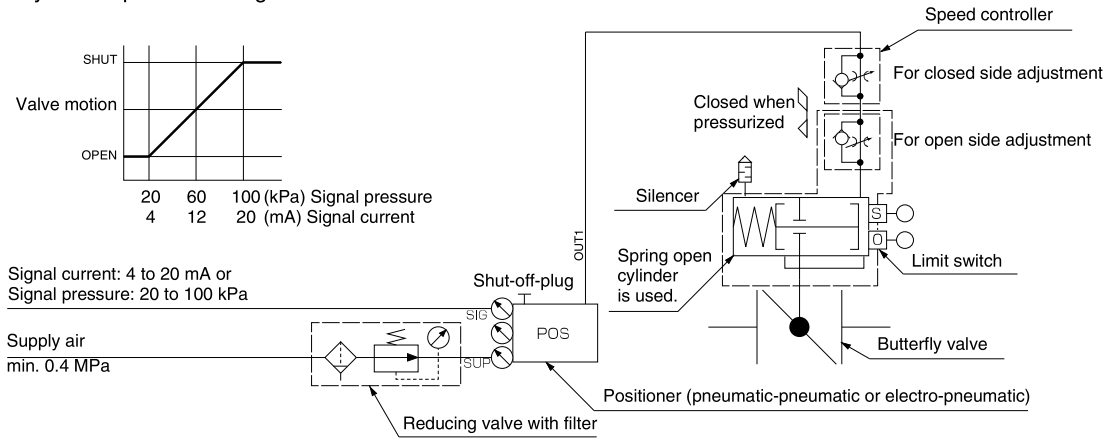

→Butterfly valve opens when air supply fails.

4 Reverse action

Butterfly valve opens when signal increases.
Butterfly valve closes when signal decreases.

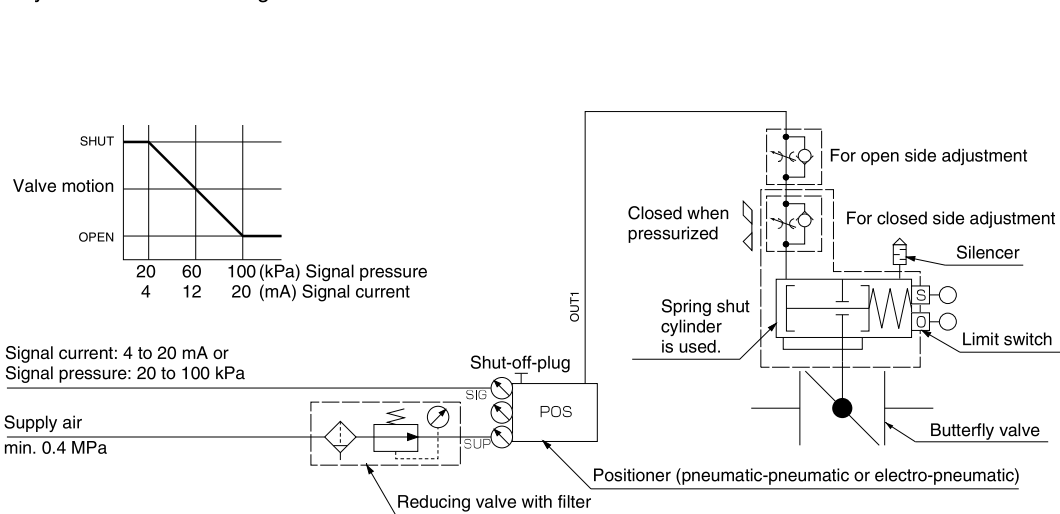

→Butterfly valve closes when air supply fails.

Actuator
New ELMY 41
New MICON ELMY II 41
PMK-SRF 4K
SRJ 4J
LTKD 4L
New T-DYNAMO 7E/7F/7G
TGA 3A
TG-S 3K/3U
3C
Diaphragm 6X/6W/6Z/6A/6B
Hydraulic cylinder 3H
Manual Actuators 17/1J/2U/2I/2S/2G/2R